



INSTALLATION & INSTRUCTION MANUAL

SN-HP-55P

SN-HP-90P

SN-HP-120P



We have provided important safety messages in this manual about your heat pump.
Always read and follow all safety messages.

 **VITAL**

This is the safety alert symbol.

This symbol alerts you to hazards that can cause injury or harm to you and others.

 **WARNING**

This is a very important label.

This symbol alerts you of things that **MUST** be strictly adhered to in order to ensure that your warranty will not be voided.

 **IMPORTANT**

These are things that must be respected in order to protect the health of spa users and to ensure that your warranty will not be voided.

Table of Contents

Introduction	3
Specifications	4
1. Safety Precautions	5
2. Outlines & Dimensions	7
3. External Appearance.....	8
4. Internal appearance	9
5. Installation Instructions	10
6. SV Controller Setup.....	17
7. Safety / Protection Systems.....	19
8. Winterizing heat pump	20
9. Temperature Sensor Calibration	23
10. Maintenance.....	25
11. Troubleshooting.....	26
12. Heat Pump Error Codes	27
13. Wiring Diagram	30
Contact Us.....	31

Introduction

Thank you for choosing the SpaNET SV Series heat pump. Air sourced heat pumps are currently the most efficient and cost-effective method of heating and maintaining the heat of your spa pool water. The SpaNET SV Series heat pump technology maintains your spa's water temperature using around 75% less energy than a conventional electric heater, and 50% less energy than natural gas, resulting in an eco-friendly and amazingly cost efficient appliance. It also allows for maximum heating input and reduced heating times on low amperage power supplies.

SpaNET SV Series heat pumps have been specifically designed to integrate to SpaNET SV Series spa controllers. SpaNET heat pumps will NOT operate on any other spa control system. They do not have a separate keypad for adjusting settings; rather they feature a dedicated interface to the SV Series spa controller allowing all temperature settings and mode adjustments to be conveniently controlled via the spa side keypad.

They offer a truly integrated heat pump solution for a spa pool that can not only provide automatic heating of the spa water, but automatic cooling of the spa water as well. Simply set your desired water temperature on the spa side keypad and the SV heat pump will automatically heat or cool the water (when required) to maintain your desired water temperature level (from 10°C to 41°C). They offer outstanding efficiency, low noise and high build quality. They are easy to use and maintain and when installed correctly will provide years of trouble free service.

Please read this instruction manual carefully before use and follow all installation guidelines in order to prevent damage to the device and ensure long term reliability.

Specifications are subject to change without notice for further improvement.

IMPORTANT

- 1) In extreme cold weather (ongoing temperatures below 0°C), when the heat pump is no longer needed, it is important to isolate water flow to the heat pump and drain out all the water inside the heat pump. Please refer to the “Winterising” section of this manual.
- 2) The heat pump should NOT be installed in an airtight location or confined space, such as a basement or garage. The heat pump requires good air ventilation. It will discharge cold air when it is heating and hot air when it is cooling, and its efficiency depends on its ability to draw normal ambient temperature air and discharge the cold or hot air well away from the unit. It is recommended to install the heat pump away from any other home appliances, to avoid the chance of electromagnetic interference. Please refer to the “Air Space Requirements” section of this manual.

Specifications

Description	SN-HP-55P	SN-HP-90P	SN-HP-120P
Power supply	220-240V~/1PH/50Hz	220-240V~/1PH/50Hz	220-240V~/1PH/50Hz
HEATING TEST CONDITION:	Air Temp = 25°C Water Temp = 27°C	Air Temp = 25°C Water Temp = 27°C	Air Temp = 25°C Water Temp = 27°C
Heating capacity	5.6Kw	8.6Kw	12.0Kw
Heating input	1.1Kw	1.65Kw	2.2Kw
COP	5.1	5.21	5.45
Running current heating	5.3A	7.8A	10.8A
Cooling capacity	3.8Kw	5.3Kw	8.4Kw
Cooling input	1.3Kw	2.0Kw	2.4Kw
Maximum rated cooling current	5.8A	8.5A	11.5A
Refrigerant	R410A, 600g	R410A, 950g	R410a, 1400g
Air Flow (m ³ /H)	1600	1700	2600
Sound pressure level	<49 dB(A)	<49 dB(A)	<51 dB(A)
Protection class	1	1	1
Waterproof class	IPx5	IPx5	IPx5
Net weight	45Kg	53Kg	62Kg
Fan speed	850 RPM	850RPM	1000RPM
Water temperature range	10 to 41°C	10 to 41°C	10 to 41°C
Operating temperature range	0°C to 40°C	0°C to 40°C	0°C to 40°C
Minimum water flow rate	2.2 m3/hr	3.0 m3/hr	4.0 m3/hr
Cabinet dimensions L x W x H	96 x 32 x 54 cm	96 x 32 x 54 cm	98.5 x 33 x 62 cm
Heat exchanger	Titanium + PVC	Titanium + PVC	Titanium + PVC
Expansion valve	Mechanical	Mechanical	Mechanical
Outlet size	40mm	40mm	40mm
Defrost element	40W	40W	40W
B Fuse	IEC 20A time delay, 250V	IEC 20A time delay, 250V	IEC 20A time delay, 250V

1. Safety Precautions



Electrical power must be switched off before starting any work on heat pump. **DO NOT** attempt to modify the internal configuration of the heat pump. Read the entire installation manual before use or service.

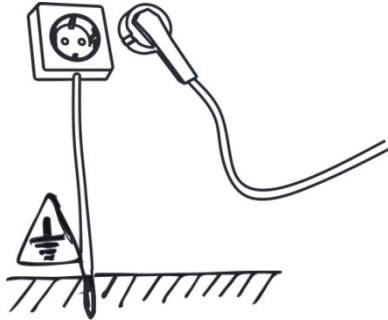

The unit must be earthed to avoid any risks caused by insulation defects. The heat pump will be earthed via the preinstalled AMP power cable which connects to the SV spa control. If a different power source is used, ensure heat pump is connected to earth.

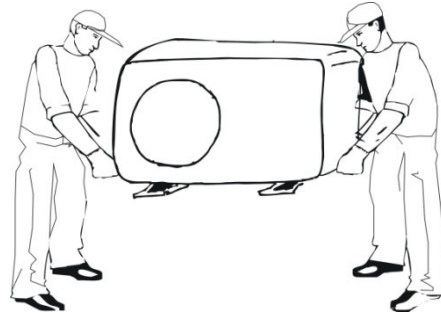

The installation, commissioning and maintenance of these machines should be performed by qualified personnel having a good knowledge of standards and local regulations, as well as experience with this type of equipment.



You can clean the evaporator by washing with detergent and water at low pressure, and then rinsing with clean water.

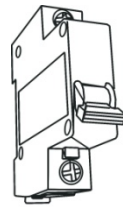

Steel Wire



Copper Wire



- It is the responsibility of the installer to ensure circuit breaker protection, considering the spa pool and heat pump capacity. The SV spa control and heat pump should also be supplied through a residual current device (RCD) having a rated residual operating current not exceeding 30mA.

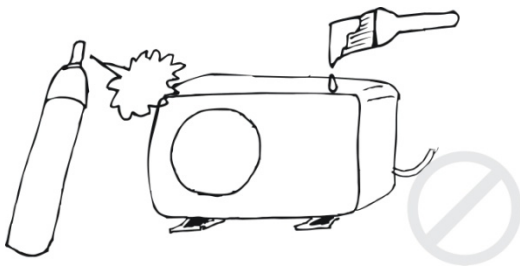

Do not spray or paint insecticidal material on the surface of the unit.

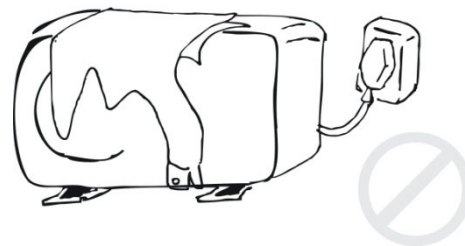

Do not block the evaporator by paper or any other foreign bodies, to keep the unit well ventilated.

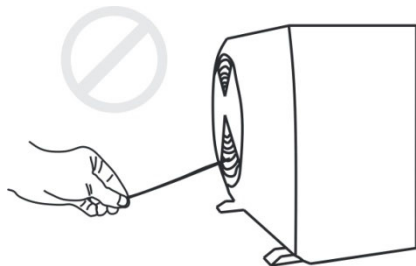

Do not touch the air outlet grill when fan motor is running

*** This appliance is not intended for use by persons (including children) with reduced physical, sensory or mental capabilities, or lack of experience and knowledge, unless they have been given supervision or instruction concerning use of the appliance by a person responsible for their safety.**

Children should be supervised to ensure that they do not play with the appliance.

VITAL

Unless you are certain the heat pump has always remained in its upright installation orientation during transit and throughout the installation process, and has not been laid on its side or end at any time, the heat pump should NOT be used for 24 hours after its installation to prevent damage to the compressor.

- The SV heat pump is preinstalled with an AMP power cable for direct power connection to the SV spa control. If the installer decides to connect power to the heat pump from a source other than the SV spa control, all electrical connections must be performed by a licensed electrician and must confirm to all national, state and local electrical codes in effect at the time of installation.
- The SV spa control must be connected to a suitable rated and weather protected power supply. The supply line should be a dedicated power circuit and means for disconnection must be incorporated in the fixed wiring in accordance with your local wiring regulations. Means for disconnection from the supply mains should have a contact separation in all poles that provide full disconnection under over voltage Category III conditions. If the SV heat pump does not source power directly from the SV spa control these precautions should also be followed for the heat pump power supply.
- The appliance contains no serviceable parts. Do not attempt service of this appliance. Contact your dealer or authorized service agent for assistance.
- Turn the mains power OFF before touching or modifying any cable connection.
- Low voltage or improper wiring may cause damage to this appliance. Read and follow all wiring instructions when connecting to power supply.
- If the supply cord is damaged, it must be replaced by the manufacturer, its service agent or similarly qualified persons in order to avoid a hazard.
- This appliance must not be installed in proximity to highly flammable materials.
- Water temperature in excess of 38°C may cause hyperthermia (heat stress).
- It is the installer's responsibility to ensure the floor or mounting base is capable of supporting the expected load of the heat pump and an adequate drainage system has to be provided in case of overflowing or leaking water.
- The heat pump should be plumbed after the spa filters and NOT before, to prevent foreign objects or debris from entering heat pump.
- Spanet series heat pumps can only be used with Spanet series SV controllers.

WARNING

When ambient temperatures are close to or under freezing point, water circulation to the heat pump should never be stopped for more than 4 hours without completely draining the heat exchange. **In areas where freezing conditions are prevalent and sustained, in advance of any freeze event, all water MUST be removed from the entire heat pump water circuit. Please refer to the “Winterising” section of this manual. FREEZE DAMAGE NOT COVERED UNDER PRODUCT WARRANTY**

2. Outlines & Dimensions

SN-HP-55P and SN-HP-90P

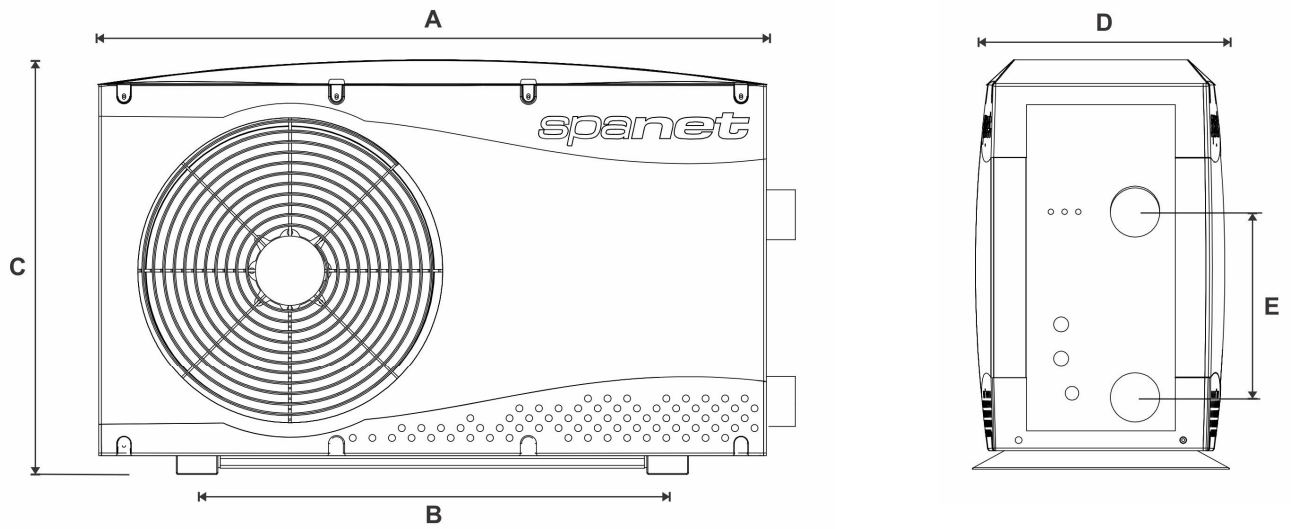

Model	A	B	C	D	E
SN-HP-55P	960mm	705mm	615mm	320mm	280mm
SN-HP-90P	960mm	705mm	615mm	320mm	290mm
SN-HP-120P	980mm	615mm	615mm	312mm	300mm

SN-HP-120P

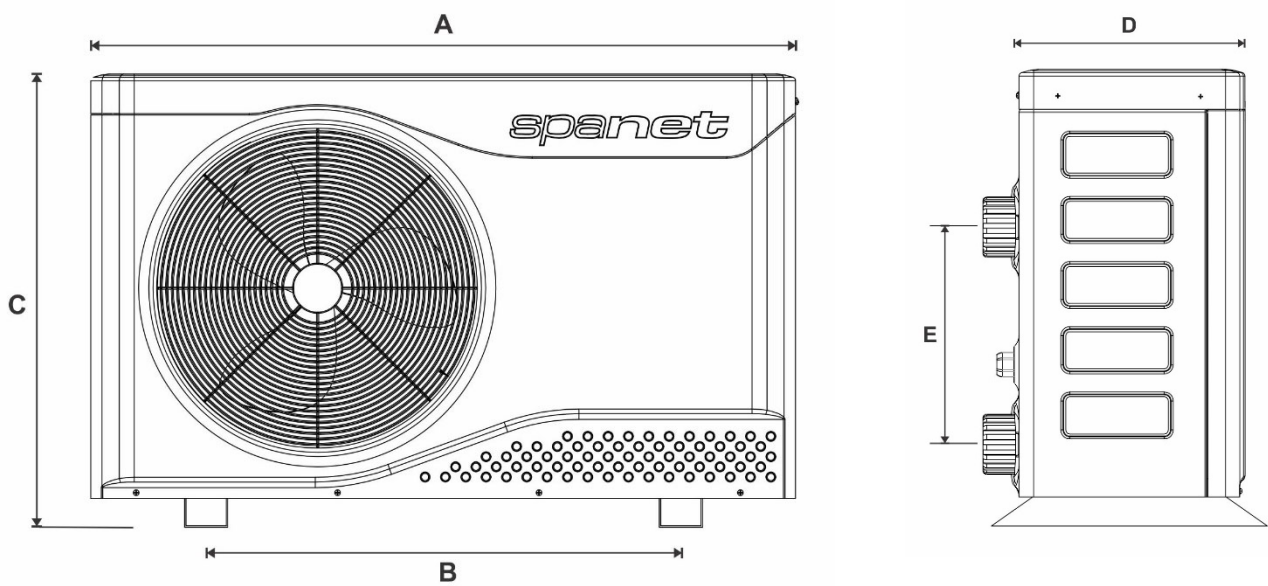

3. External Appearance

SN-HP-55P and SN-HP-90P

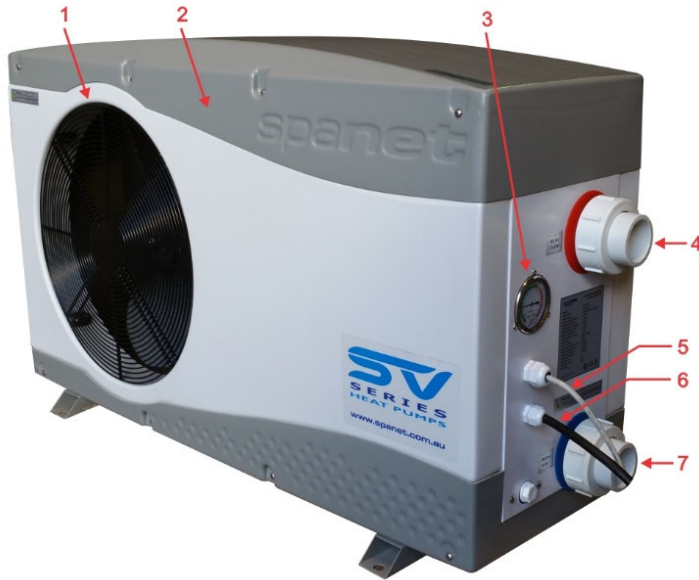

1	Fan protection grill (exhaust side)
2	ABS/ASA plastic cabinet
3	Refrigerant pressure manometer
4	Water outlet
5	Data cable
6	Power cable
7	Water inlet

SN-HP-120P



4. Internal appearance

(Front sheet cover and panel removed)

8	Evaporator
9	Fan
10	Compressor
11	4-way-valve
12	Titanium in PVC heat exchanger
13	Water flow switch
14	Capillary
15	Refrigerant charge valve

SN-HP-55 and SN-HP-90

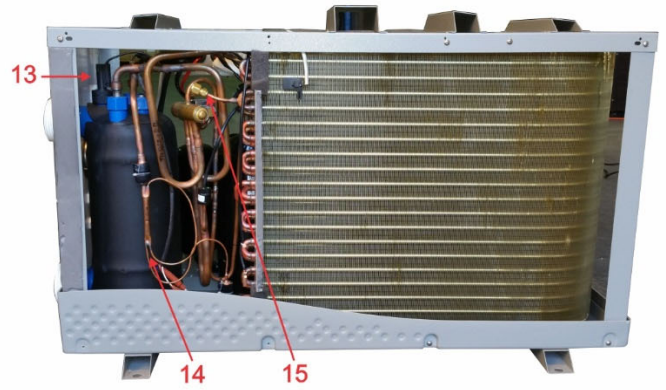
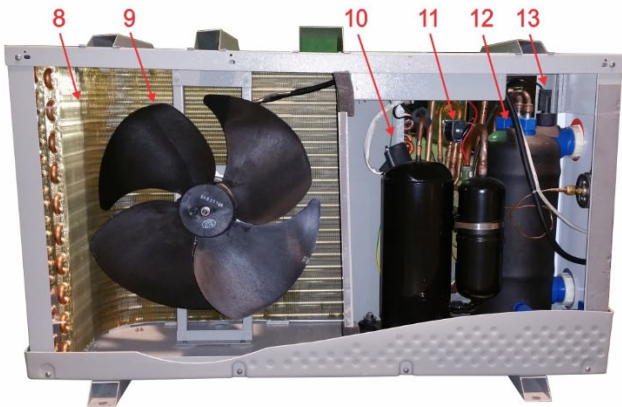

SN-HP-120

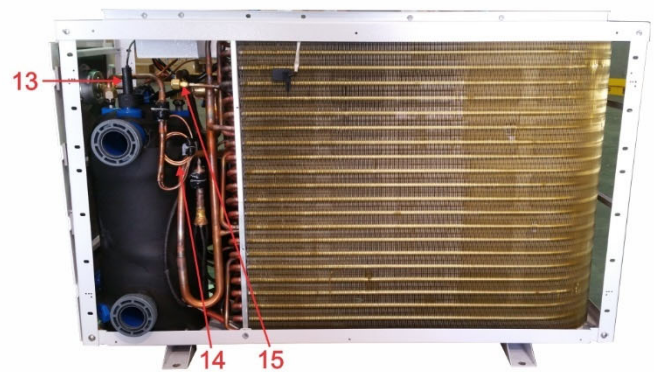
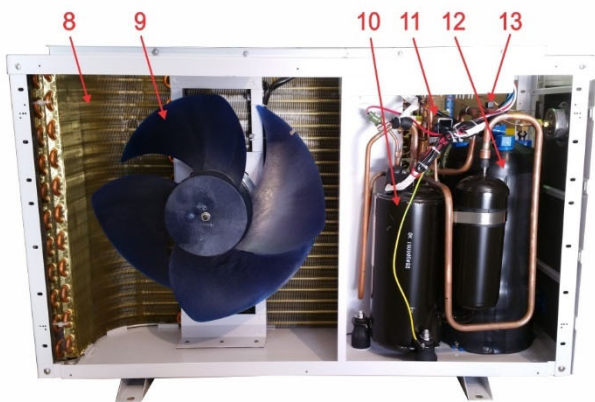

Installation Instructions

4.1 Recommended Air Flow Requirements

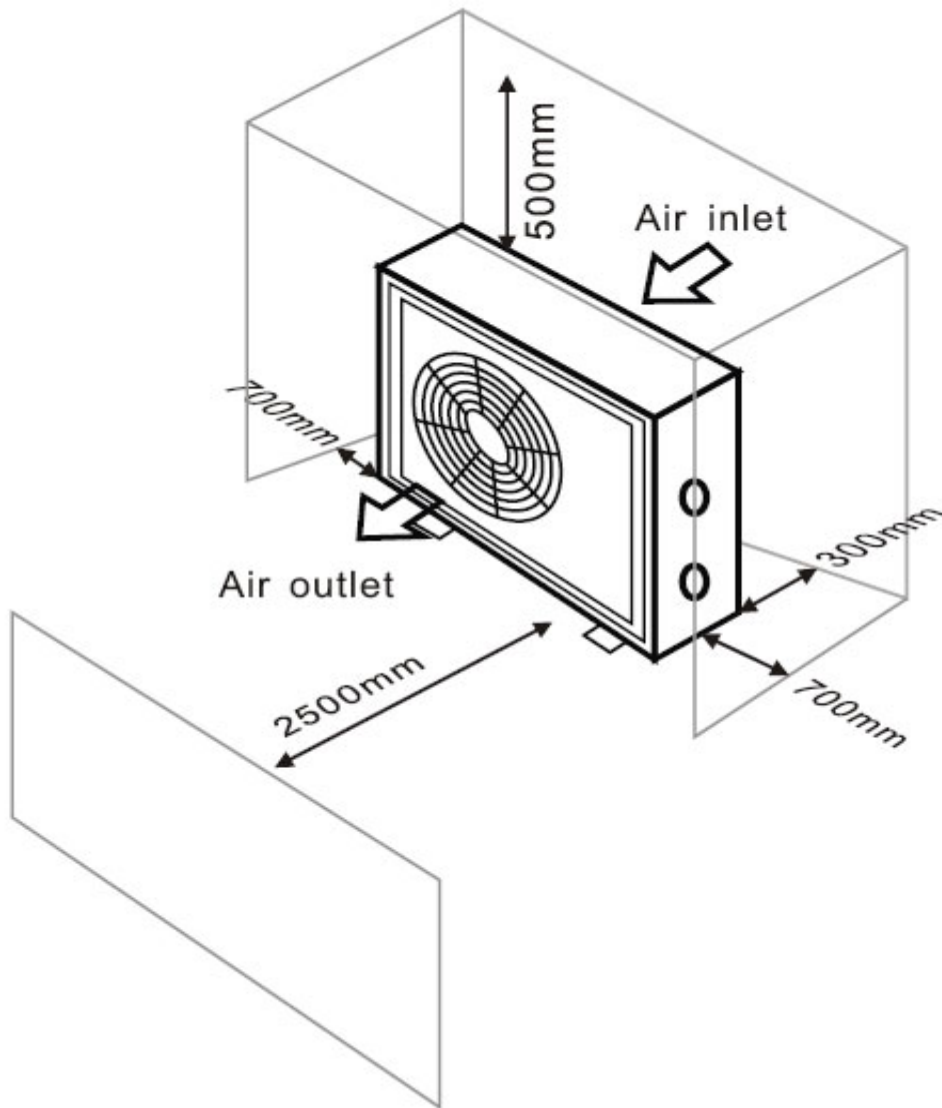

Figure 1

- The SV Series of heat pumps must be located outside in a clean area where air flow will not be restrictive. The heat pump must be located external to the spa pool cabinet to allow sufficient air flow for optimum efficiency.
- The heat pump must operate with a clean air supply so should be situated away from vegetation and obstacles.

⚠ WARNING

The heat pump **MUST** be installed according to the air space requirements shown in Figure 1. Failure to follow these instructions may VOID WARRANTY.

4.2 Location of the unit

Select a suitable location in accordance with below notes and consult the local swimming pool safety regulations to check requirements for proximity to other equipment.

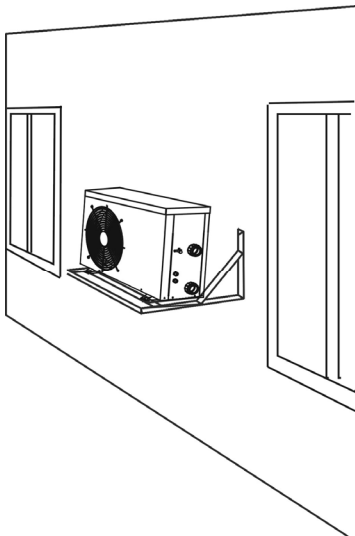

Install on wall

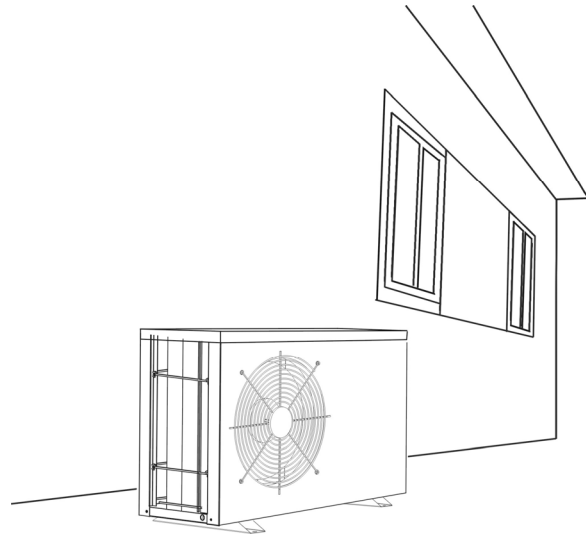

Install on ground



INSTALLATION LOCATION NOTES:

1. The heat pump must be installed on a flat, solid and large enough base to properly secure the heat pump. Whilst it can be mounted on brackets or stands a level concrete base is preferred.
2. If installing the heat pump in a harsh climatic area (i.e. sub-zero temperatures, snow, humidity), it is recommended to raise the unit 50cm above the ground.
3. During installation, ensure sufficient free space is left around the heat pump for future maintenance.
4. The unit is air cooled. It must be installed outdoor in an area with sufficient clearance to provide enough air circulation through evaporator.
5. DO NOT install heat pump in a confined space to prevent recycling of air.
6. The fan should not blow towards windows, walls or spaces likely to be inhabited by people or animals.
7. Do not install where the heat pump is likely to be subjected to polluted air, dust or debris etc.
8. Avoid directing fan output against the dominant wind directions.
9. Protect the heat pump from possible snow fall.
10. Minimise exposure to environmental conditions as much as possible and never block the airflow.
11. Ensure the heat pump is installed in an area that is free from flammable and corrosive chemicals, and grease.

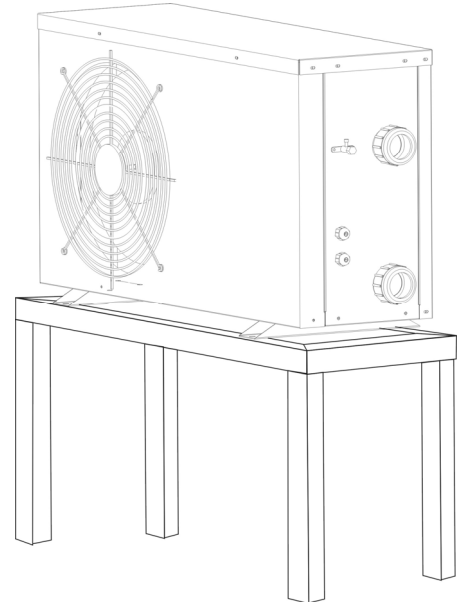

Install on stand

4.3 Pipework insulation

In order to keep power consumption to a minimum, it is recommended that all external pipe work connecting the heat pump to the spa pool should be insulated.

4.4 Condensation drain

During humid conditions, as part of the heat exchange process the evaporator may produce a lot of condensation. Please install the drain connector as shown in the picture aside, so the condensation run off can be directed to a suitable location. In very cold climates (i.e. ambient temperatures below 0°C) the drain connector should not be used to prevent becoming blocked with ice during periods of idle activity.

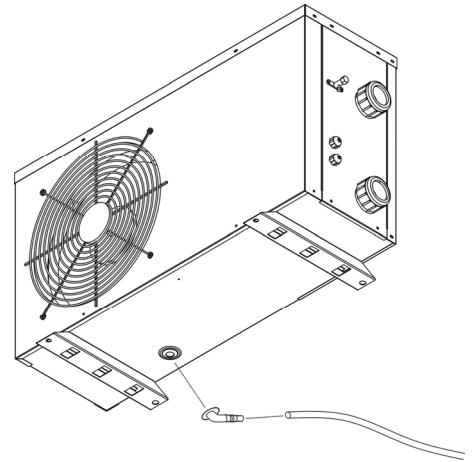

4.5 Installation of water pipes

4.5.1 Glued Union Fittings

1. Ensure both tail piece and locking ring are screwed/fitted to the heat pump and tightened before gluing water pipe to union tail. This will ensure the tail piece has an even seal against the o-ring.
2. Use PVC priming fluid on end of water pipe and union tails before gluing. Once primed glue pipes into place and ensure pipes are running straight and square into heat pump.

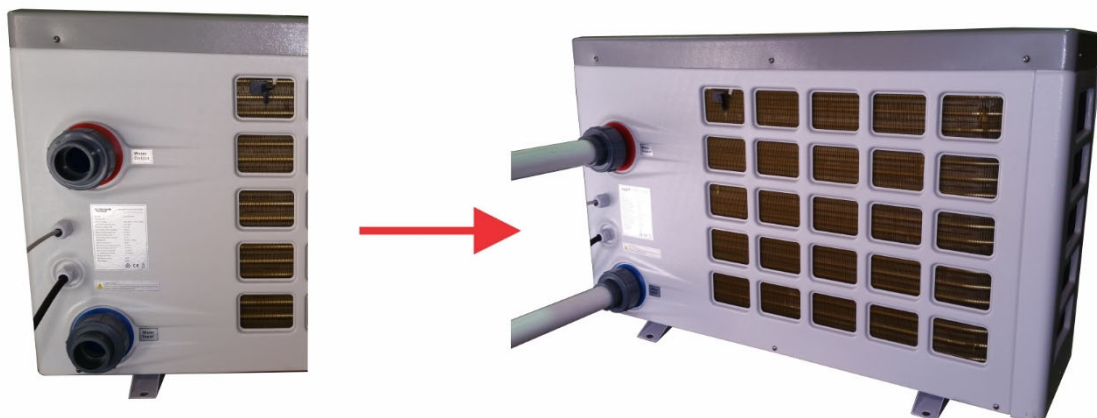
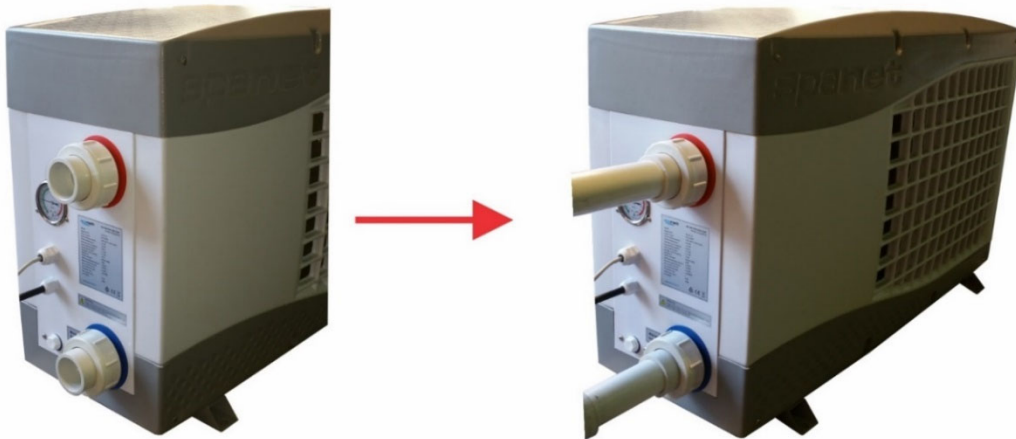

 **IMPORTANT**

Ensure the pipe work running from the heat pump to the spa pool is supported. DO NOT have long runs of pipe in mid-air above the ground without support. Ideally return the pipes to ground level as they exit the heat pump to ensure the pipe work is self-supporting.

NOTE: Once the pipe work is full of water it will become heavy and will place strain on the heat pump outlets if the pipe work is not supported. In the case of glued union fittings, if the pipe work is unsupported the strain could cause stress damage to the outlets and potential leaks.

IT IS THE INSTALLER'S RESPONSIBILITY TO ENSURE THE PIPE WORK IS ADEQUATELY SUPPORTED AND RESTRAINED TO PREVENT MOVEMENT AND STRESS.

4.6 Plumbing Instructions and Diagram

The SV heat pump outlets require 40mm PVC pressure pipe to be used.

Ideally the heat pump should be plumbed inline prior to the SV controller, so that water flows from the filter pump, through the heat pump and then back through the SV controller before returning to the spa. This provides a second level of safety thermal protection for the water returning to the spa. The heat pump will still work if plumbed after the SV controller however being plumbed prior to the controller is the preferred option where possible.

The installer should ensure that all pipe work is supported and restrained to prevent movement and stress. Also it is recommended that all pipe work external to the spa is insulated.

Refer to plumbing diagram on following page for more information.

Basic heat pump plumbing diagram

IMPORTANT

The heat pump should be plumbed inline **PRIOR** to the SV controller where ever possible. Water should flow out of the heat pump and through the SV controller before returning to the spa.

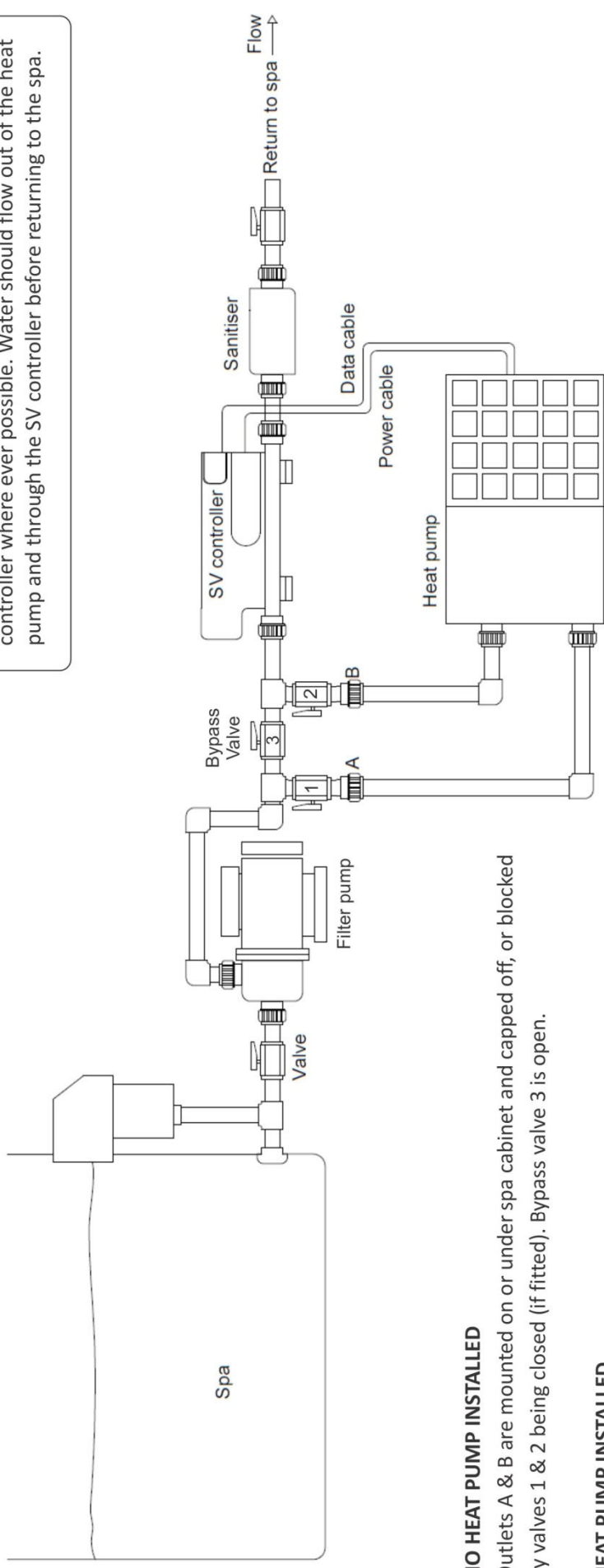

NO HEAT PUMP INSTALLED

Outlets A & B are mounted on or under spa cabinet and capped off, or blocked by valves 1 & 2 being closed (if fitted). Bypass valve 3 is open.

HEAT PUMP INSTALLED

Heat pump inlet and outlet pipes connect to points A & B. Valves 1 & 2 (if fitted) are open.

Circ Pump Setup

Bypass valve 3 is 100% closed

2speed Pump/V80 Setup

Bypass valve 3 is 60% / 40% (i.e. 60% closed / 40% open)

NOTES:

1. Heat pump powered from SV controller 230V socket OR any 230V power source (requires constant power)
2. Heat pump data cable connected to SV controller port (EXP2)
3. Pipe work external to spa cabinet should be insulated
4. All pipe work should be supported and restrained to prevent movement and stress

4.7 Cable Connections

Data and power cables must be installed between the heat pump and spa pool in accordance with the local wiring regulations. **It is best practice to separate data and power cables from each other.**

4.7.1 Power Cable Connection

The SV heat pump requires connection to a constant 230V power supply. The heat pump can source power directly from the SV spa controller or can be connected to a 30mA RCD protected 230V power circuit. The easiest and recommended method is to use the heat pump's preinstalled AMP power cable and connect to a **230V OUTLET** on the front of the SV spa controller.



SV3 /SV4 models feature 2 x 230V power outlets
SV2 models feature 1 x 230V power outlet

NOTE: It is recommended to use the last AMP power outlet labeled “230V OUTLET” on the right hand side of the SV spa controller unless otherwise advised by your spa reseller or licensed electrician.



AMP SOCKETS & PLUGS

SV series spa controllers utilise AMP mate-N-lok power connectors. The AMP connectors feature a key pattern for fail safe one way connection. When connecting the heat pump be sure to push cordset firmly into socket and ensure both side locking tabs have been secured and latched in place.

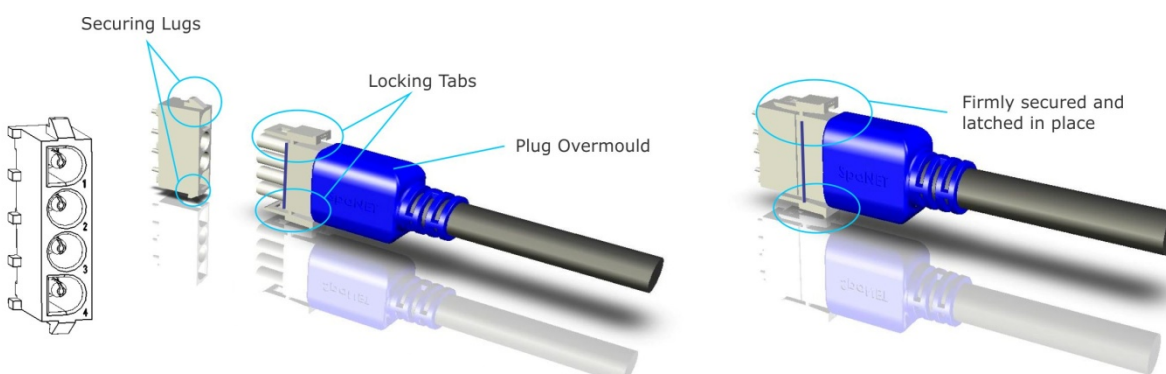

4.7.2 Data Cable Connection

The SV heat pump is a slave device and is operated by the SV spa controller. It requires a data cable connection for communication between the SV controller and the heat pump itself. The data cable should be connected to the **EXP2 (heat pump)** socket in the low voltage connection area of the SV controller (refer below instructions).

1. Unscrew and remove low voltage ports cover from top right corner of spa controller
2. Connect heat pump data cable into RJ45 socket labelled **EXP2** (refer aside). It is the second socket down on the left hand row of sockets
3. Route the data cable up through the cable guide provided, ensuring the data cable has a drip loop before it enters the enclosure
4. Reattach and screw low voltage ports cover back in

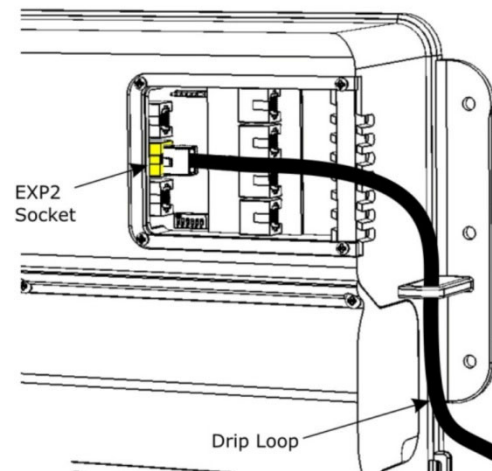

⚠ WARNING

It is imperative to ensure adequate separation between the communications (data) cable and power cable running from the heat pump to the spa to prevent data corruption. The data and power cables should NOT be tied side by side or placed in a shared conduit. Rather they should be separated by a distance of 150-300mm.

A suggested practice is to secure one cable to the inlet pipe and the other cable to the outlet pipe. The cables can come together to enter the heat pump and the spa cabinet however they should be separated everywhere else. Also if there is excess cable left over under the spa cabinet, ensure the power and data cable remain separated and are not left in a bundle together.

👉 IMPORTANT

If the data and/or power cables supplied with the heat pump are insufficient in length to reach the SV controller DO NOT cut and extend the cables. The cables must be replaced in entirety with new longer cables. Failure to follow this instruction will VOID WARRANTY. 10M cable sets can be purchased if required (**only use double-shielded CAT5/CAT6 Ethernet cable**).

⚠ VITAL

If the preinstalled data cable is replaced with a longer cable it is vital that the heat pump temperature sensors are recalibrated to ensure defrost cycles operate correctly in cold climates. Failure to adjust the calibration may cause the heat pump to ice up during periods of low temperatures (< 5°C). Refer to the "Temperature Sensor Calibration" section of this manual.

5.8 Initial Start-up

1. Once the plumbing to the heat pump has been completed and been given sufficient time for the PVC cement/glue to cure, the pipe work should be bled of any air. With the spa power turned OFF, the valves should be adjusted to provide water flow to the heat pump. Then the top coupling on the heat pump outlet pipe should be slightly loosened to allow the air in the pipe work to escape. Once the air has escaped and there is a constant stream of water, re-tighten the outlet coupling sufficiently.
2. With the power and data cable remaining DISCONNECTED from the SV controller, supply power to the spa and operate the filtration pump to complete purging any air from the heat pump and pipe work. Allow filtration pump to run and ensure you can see and feel the water returning to the spa. (NOTE: If you cannot see the water returning to the spa, turn the power OFF immediately and attempt to bleed the air from the pipe work by loosening the coupling on the heat pump again, and/or at the filtration pump couplings if required. Be sure to re-tighten all couplings after bleeding the air).
3. Once the air has been bled and water is freely flowing and returning to the spa, operate the filtration pump for several minutes and check for drips and leaks from the pipe work. Take corrective action to resolve any drips/leaks if present.
4. Now that the pipe work has been bled of air and has been checked for leaks it is time to turn the spa power back OFF and connect the heat pump power and data cables to the SV controller (refer to the "Cable Connections" section of this manual).
5. Once power and data cables have been connected and power is restored to the spa pool the SV controller will automatically detect that the heat pump is connected and disable the internal electric element, and will engage the heat pump for heating and/or cooling where required to maintain the desired water temperature in your spa pool.

6. SV Controller Setup

All models of the SV Series spa controllers have the capability to seamlessly integrate and control a SV Series heat pump for efficient heating and cooling of the spa water. When a SV Series heat pump is connected the SV controller will automatically detect the heat pump and take control of its operation. All heat pump functions including heating / cooling / temperature adjustment / defrost cycles / over temp protection / diagnostics and monitoring are all controlled by the SV spa controller and the SV spa side touch pad. There is no system setup required, it will simply detect the heat pump and use it. However, the SV spa controller offers two setup menu options (H.PMP and H.ELE) for tailoring the heat pump operation:

6.1 Heat Pump Operating Mode (H.PMP)

This setting determines how the heat pump should operate. There are four operating modes:

H.PMP SETTING	DESCRIPTION
AUTO	Heat pump will heat and cool
HEAT	Heat pump will only heat
COOL	Heat pump will only cool (SV element heating also disabled)
OFF	Heat pump is disabled

Depending on your SV controller firmware version the H.PMP mode will either default to AUTO or HEAT. **In order to keep power consumption to a minimum we recommend setting H.PMP=HEAT.** This will only allow the heat pump to operate to heat the water. If H.PMP=HEAT and the set temperature is lower than the actual water temperature the heat pump will NOT engage to cool the water, allowing the water to cool naturally.

If however H.PMP=AUTO the heat pump will heat and cool the water. So if the set temperature is lower than actual water temperature the heat pump will engage to cool the water down. This may be desired in the warmer months of the year but it not recommended in Winter where you may want to lower the set temperature because the spa is not being as often and you do not want to pay the electricity cost for the heat pump to cool the water.

6.1.1 Adjusting heat pump operating mode (H.PMP)

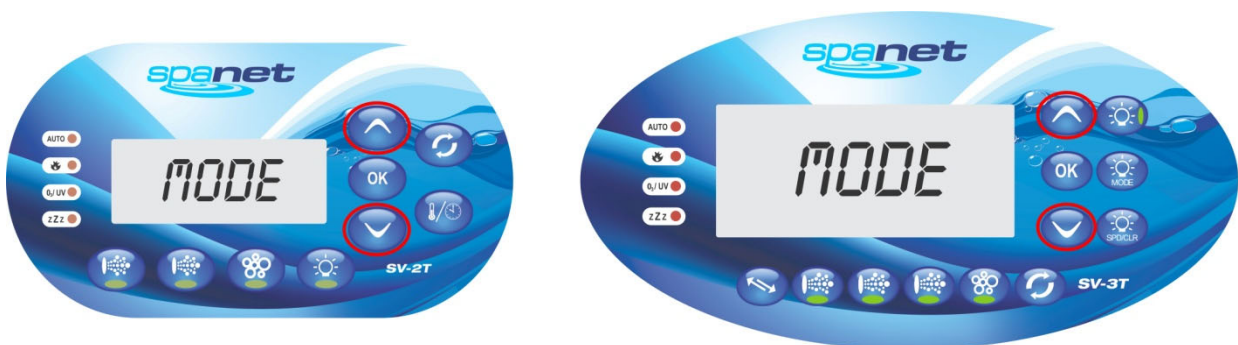

1. Press and hold UP + DOWN buttons simultaneously until display shows “MODE” (refer above)
2. Press the DOWN button until display shows “H.PMP” (heat pump mode)
3. Press the OK button to enter the H.PMP mode adjustment
4. Use the UP or DOWN buttons to select either AUTO/HEAT/COOL/OFF
5. Press the OK button to confirm and save the setting

IMPORTANT

NOTES ON COOLING

The heat pump has principally been designed for cost efficient heating of your spa pool. Through the use of refrigeration technology we are able to run the heat pump in reverse cycle to cool the spa water as well. However there are operating limits for the refrigerant.

In extreme environmental weather conditions (i.e. ambient temp > 40°C), depending on heat pump location & environment (i.e. direct sunlight, undercover) and nearby obstructions and air flow restrictions (i.e. fences, plants, walls) if the heat pump is used for COOLING, the refrigerant MAY exceed its working capacity and shut down on high pressure error. To prevent this, **the heat pump should only be used for COOLING at times of day/night when ambient temperatures are lower, and prior to any extreme hot weather event.**

6.2 Heat Pump with SV Element Boost (H.ELE)

This setting defines how the SV electric heating element operates when a SV series heat pump is installed. The benefit of this feature is that the internal electric SV heater can be set to operate in conjunction with the SV heat pump to boost heating and reduce heating times. There are two setting choices:

H.ELE SETTING	DESCRIPTION
OFF	Heat pump only (SV element disabled)
ON	Heat pump + SV element

By default the H.ELE setting will be set to OFF, so that only the heat pump is used for heating.

6.2.1 Adjusting heat pump with SV element boost (H.ELE)

1. Press and hold UP + DOWN buttons simultaneously until display shows "MODE"
2. Press the DOWN button until display shows "H.ELE"
3. Press the OK button to enter the H.ELE setting adjustment
4. Use the UP or DOWN buttons to select either OFF/ON
5. Press the OK button to confirm and save the setting

IMPORTANT

If H.ELE=ON the SV spa controller's electric heating element will operate in conjunction with the heat pump to boost heating **only** if the water temperature is 2°C or more below the set temperature point **OR** the heat pump has been operating for more than 1 hour and the set temperature point has not been reached.

NOTE: If the ambient temperature is below the operational limit of the heat pump (-2°C) the SV electric element will be enable regardless of the H.ELE setting. The heat pump is latched in standby mode. When the temperature rises above -2°C the heat pump is allowed to operate normally.

7. Safety / Protection Systems

SV Heat pumps are equipped with the following safety protection systems:

1. Water flow switch

The heat pump is fitted with a flow switch to prevent the heat pump from operating and overheating the water in the heat exchange tank if there is too little or no water flow through the heat pump. The flow switch must close within 30 seconds of the heat pump starting to prevent a "HEAT PUMP FLOW" error.

2. Refrigerant gas high and low pressure protection

The high pressure protection makes sure the heat pump is not damaged in case of over pressurisation of the gas due to insufficient water flow or high ambient temperatures. The low pressure protection identifies when refrigerant has escaped from the conduits and the unit cannot be kept running.

3. Compressor over temperature protection

This thermal cut out switch protects the compressor from overheating.

4. Automatic defrost control

When the air is very humid and cold, ice can form on the evaporator. In such situations, a thin layer of ice appears that will grow increasingly bigger as long as the heat pump is running. When the temperature of the evaporator has become too low, automatic defrost control will be activated, which will reverse the heat pump cycle so that hot refrigerant gas is sent through the evaporator for a brief period of time to defrost it. During a defrost cycle the ice will melt and generally will create steam.

5. Anti-freeze protection during winter

For freeze protection we have multiple protection methods in place:

- If heat pump ambient sensor detects temperatures lower than 3°C the 40W defrost element is switched on inside the heat pump to help keep the condenser and heat exchanger warm. This element will switch off once ambient temperature rises above 3°C.
- If heat pump ambient sensor detects temperatures of 1°C or lower the defrost element and filtration pump are switched on to run continuously until ambient temperature rises above 1°C. Sleep and power save timers are ignored. Freeze protection overrides any programmed timers.

8. Winterizing heat pump

Winterizing is a procedure that prepares your heat pump for freezing conditions. In areas where freezing conditions are a rare and brief occurrence, the water filtration system can be programmed to run continuously throughout the freeze period. Typically, during light freeze conditions circulating (moving) water will not solidify.

However in areas where freezing conditions are prevalent and sustained, and the spa is to be turned OFF during the winter period, in advance of any freeze event, all water **MUST** be removed from the entire heat pump water circuit including heat exchanger. Freezing of the unit will severely damage the heat exchanger and other components due to water/ice expansion. Damage resulting from a failure to properly winterize is **NOT** covered under the heat pump product warranty.

8.1 Preparing for light freeze conditions

When ambient temperatures are close to or under freezing point, water circulation to the heat pump must never be stopped for more than 4 hours. To ensure this certain SV spa controller setup menu software settings should be adjusted/checked prior to occurrence of light freeze events. Carry out the following:

8.1.1 Disable both sleep timers

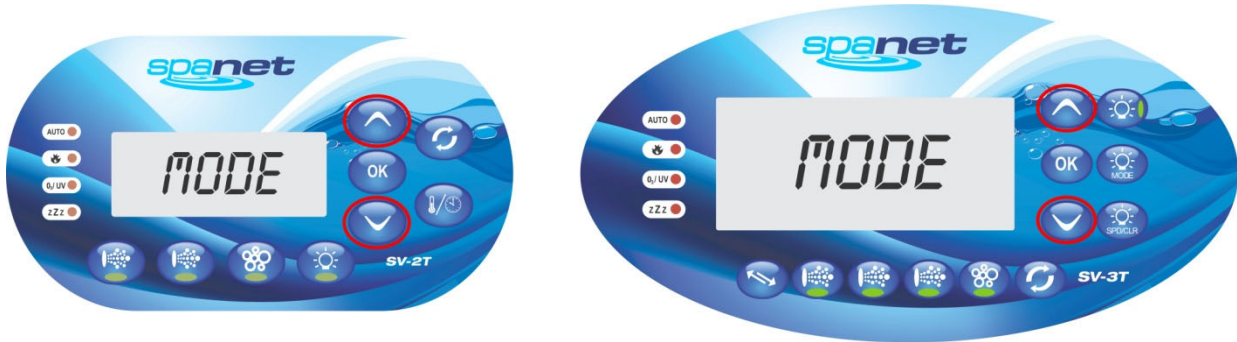

1. Press and hold UP + DOWN buttons simultaneously until display shows “MODE” (refer above)
2. Press the UP button until display shows “SNZE”
3. Press the OK button to enter the SNZE (sleep timer) adjustment => “1.SNZ” is displayed
4. Press the OK button to enter 1.SNZ (first sleep timer) programming => “1.DAY” is displayed
5. Press the DOWN button to adjust 1.DAY setting until the semicolon “ : ” (disabled) sleep timer icon is displayed or display shows “OFF”
6. Press the OK button to confirm and save the setting
7. Re-enter SNZE menu and when display shows “1.SNZ” press the UP button so the display shows “2.SNZ” (second sleep timer)
8. Press OK button to enter 2.SNZ (second sleep timer) programming => “2.DAY” is displayed
9. If not already showing the “ : ” (disabled) symbol or “OFF”, use the DOWN button until display shows “ : ” or “OFF”
10. Press the OK button to confirm and save the setting

8.1.2 Set filtration to 24 hour circulation

1. Press and hold UP + DOWN buttons simultaneously until display shows “MODE”
2. Press the UP button until display shows “FILT”
3. Press the OK button to enter the FILT (daily filtration runtime) adjustment
4. Press the UP button to increase daily filtration runtime to twenty-four hours “24 HR”
5. Press the OK button to confirm and save setting

8.2 Preparing for freezing conditions

If the heat pump is located in an area where the temperature drops below the freezing point of 0°C, and the spa is to be shut down and turned OFF for the winter period, it is mandatory that the water accumulated in the heat pump be drained completely before freezing weather occurs. To prevent damage from freezing perform the following steps:

8.2.1 Disable heat pump on SV controller (adjust H.PMP)

1. Press and hold UP + DOWN buttons simultaneously until display shows "MODE"
2. Press the DOWN button until display shows "H.PMP" (heat pump mode)
3. Press the OK button to enter the H.PMP mode adjustment
4. Use the UP button to select "OFF" (OFF=heat pump disabled)
5. Press the OK button to confirm and save the setting

IMPORTANT

If H.PMP=OFF the heat pump is disabled and will not be used to heat the spa. There is no need to disconnect the power or data cables from the SV controller. The SV's internal electric element will automatically be used for heating instead.

8.2.2 Isolate water flow to heat pump and drain water

1. Switch power to spa OFF.

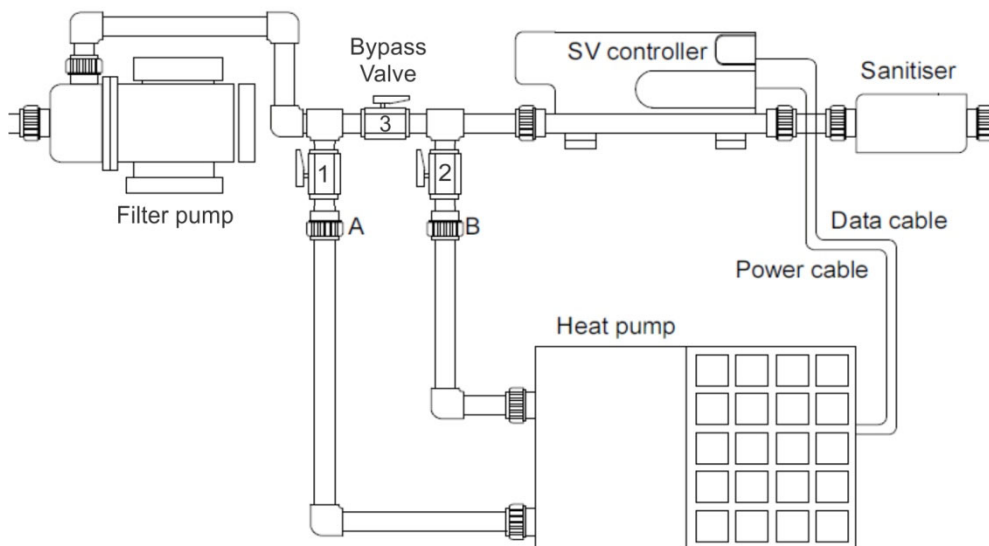

2. Close isolating valves (1 & 2) to inlet and outlet pipes of heat pump and fully open bypass valve (3) to close water supply to the heat pump and keep water circulating within the spa (refer above).
3. Drain the heat exchanger by unscrewing the drain plug found on the front of the unit (refer aside).
4. Disconnect water inlet and outlet coupler fittings and completely drain pipe work of all water.
5. It is recommended to flush the inside of the heat exchanger with a hose and drain the unit again.
6. Replace drain plug and re-attach couplers to prevent lost parts and insect / debris ingress.



8.2.3 Restart heat pump after Winter

1. Switch power to spa OFF.
2. Check heat exchanger drain plug is correctly installed and water inlet and outlet coupler fittings are tight.
3. Open isolating valves to inlet and outlet pipes of heat pump and adjust by-pass valve as required.
4. Bleed air from pipe work by loosening couplings on heat pump and filtration pump outlets. . Once the air has escaped and there is a constant stream of water, re-tighten the outlet couplings sufficiently.
5. Supply power to the spa and operate filtration pump to purge all remaining air from the heat pump and pipe work. Operate the pump for a period of time and check for drips and leak. Take corrective action where required.

8.2.3.1 Re-enable heat pump on SV controller (adjust H.PMP)

- a. Press and hold UP + DOWN buttons simultaneously until display shows "MODE"
- b. Press the DOWN button until display shows "H.PMP" (heat pump mode)
- c. Press the OK button to enter the H.PMP mode adjustment
- d. Use the DOWN button and select "HEAT" (heat only) or "AUTO" (heat & cool) mode as desired
- e. Press the OK button to confirm and save the setting



WARNING

FREEZE DAMAGE NOT COVERED UNDER PRODUCT WARRANTY

9. Temperature Sensor Calibration

Due to certain conditions, environmental factors and length of data cable, your SV Series Heat Pump may require calibration of the temperature sensors for optimum performance. In particular if you have had to replace or use a longer data cable than the original preinstalled cable it is important to ensure the temperature sensors are calibrated accurately.

NOTE: Before performing calibration of the temperature sensors please ensure the heat pump has not been operated for at least 2 hours prior to calibration, to ensure that the sensor readings are unaffected by operating conditions. If the heat pump has been operated in cold conditions with un-calibrated sensors and the condenser has iced up, the ice should be removed with tepid water and heat pump left powered off for at least 2 hours prior to calibration.

9.1 Disable heat pump on SV controller (adjust H.PMP)

For accurate sensor calibration we recommend the heat pump be temporally disabled to prevent it from operating during the calibration process:

1. Press and hold UP + DOWN buttons simultaneously until display shows "MODE"
2. Press the DOWN button until display shows "H.PMP" (heat pump mode)
3. Press the OK button to enter the H.PMP mode adjustment
4. Use the UP button to select "OFF" (OFF=heat pump disabled)
5. Press the OK button to confirm and save the setting

9.2 Calibrate sensors

Measure the temperature at the back of the heat pump using a good quality temperature meter, ideally a digital meter (i.e Fluke or Digitech). If a temperature meter is NOT available, lookup current temperature of the local area via the Internet.

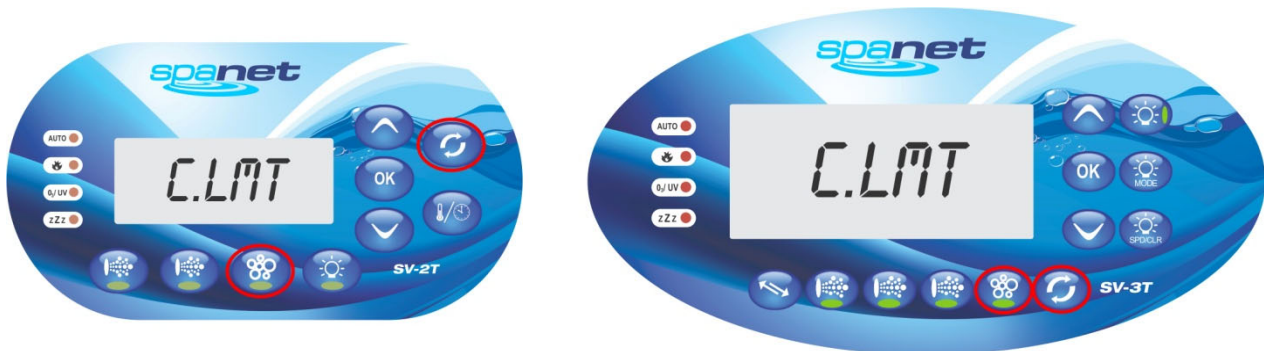

9.2.1 Calibrate heat pump ambient temperature sensor (H.AMb)

1. Press and hold BLOWER + W.CLN buttons simultaneously until display shows “C.LMT”
2. Press the DOWN button until display shows “CAL” (calibrate)
3. Press the OK button to enter CAL (calibrate) adjustments => display will show “C.ZER”
4. Press the DOWN button until display shows “H.AMb”
5. Press the OK button to enter H.AMb (ambient sensor) adjustment => display will be showing a solid or flickering temperature
6. Press the UP or DOWN buttons as required and adjust temperature reading to match measured or known outside temperate
7. Once the temperature reading matches actual press the OK button to confirm and save the setting

9.2.2 Calibrate heat pump condenser temperature sensor (H.CON)

1. Repeat steps 1-3 as above however select “H.CON” (condenser sensor) from the CAL menu and press OK to enter the sensor adjustment
2. Press the UP or DOWN buttons as required and adjust temperature reading to match measured or known outside temperate then press OK to confirm and save setting

IMPORTANT

Before performing calibration of the temperature sensors please ensure the heat pump has NOT been operated for at least 2 hours prior to calibration, to ensure that the sensor readings are unaffected by operating conditions.

9.3 Re-enable heat pump on SV controller (adjust H.PMP)

Upon completion of the sensor calibration do not forget to re-enable the heat pump by selecting “HEAT” (heat only) or “AUTO” (heat & cool) mode from the H.PMP setup menu option.

10. Maintenance

Little maintenance is required however the following should be performed on a regular basic to ensure long equipment service life.



When performing maintenance isolate power to spa pool and heat pump for safety.

1. Clean evaporator regularly in order to keep it in good performance. Use a soft brush and water containing a mild detergent or ideally specially made air conditioner cleaner. This will remove any built up dust and grime on the fins and help to restore maximum efficiency.
2. Wash the exterior of the cabinet using an automotive detergent. Remove any moss/mould or other growth. Check the cabinet for signs of corrosion or damage and remedy them. Touch up any scratches or chips in paint work and apply a coat of automotive wax to the cabinet exterior.
3. Clean spa filters regularly and keep the skimmer clear to ensure good water flow at all times.
4. Check condensation drain pipe work is clean and clear.
5. Inspect cables and pipe work for signs of damage or wear. Replace if necessary.
6. If securing bolts have been used inspect for tightness and corrosion.
7. Ensure that air space surrounding the heat pump is clear. Remove any impending vegetation or objects blocking air inlet and outlet.

10.1 Evaporator Cleaning

The evaporator does not require any special maintenance, except when it is clogged by dirt or any other debris. Cleaning is by washing with detergent and water at low pressure, and then rinsing with clean water.



1. Before cleaning, make sure the spa pool and heat pump are powered OFF.
2. Inside of heat pump must only be cleaned by a qualified person.
3. Do not use gasoline, benzene, or harsh chemicals to clean the heat pump. And do not spray with insecticide, the unit may be damaged. The cleanser specially made for air conditioner cleaning is recommended.
4. Spray air conditioner cleanser into the evaporator, let the cleanser sit for 5~8 minutes.
5. Then spray the evaporator with clean water.
6. An old hairbrush works well for brushing surface dirt and lint off the fins. Brush in the same direction as the slots between the fins so the bristles go between the fins.
7. After cleaning, use a soft and dry cloth to dry off excess water from the unit.

10.2 Refrigerant Charging

Refrigerant is very stable and should not degrade or break down even under severe operating conditions. It is not necessary to service or charge the heat pump with refrigerant unless there has been a refrigerant leak. If the unit has a leak in the sealed refrigeration system, please locate the leakage and repair before charging with more refrigerant.



Refrigerant charging must be performed by a qualified person.

11. Troubleshooting

Should a problem occur the SV spa controller will temporarily disable the heat pump and put it into error, with the touch pad display scrolling an error message every 30 seconds.



There are no user serviceable parts inside the heat pump. If a major error occurs please contact your spa reseller, service technician or a licensed professional for service.

WATER LEAKING FROM UNIT

If there is humidity in the air the heat pump will create condensation on the evaporator as part of the heat exchange process, this is normal. The higher the humidity the more condensation created. It is not uncommon for the heat pump to produce many litres of condensation; hence it is recommended that the condensation drain be installed to direct the condensation run-off to a suitable location.

The condensation will collect in the base of the machine and exit via the drain pipe under the machine. Confirm that drain pipe work is not blocked and that the machine is mounted on a level surface. If water leaking from the machine is not from condensation then all pipe work and connections should be checked for damage and leaks.

“HEAT PUMP FLOW” ERROR

The flow switch must close within 30 seconds of filtration pump operation. If a heat pump flow error occurs there is insufficient or no water flow to close the flow switch. Once a flow error has occurred, even if water flow has been re-established, mains power to the SV spa control must be reset before the heat pump will operate again.

New installations:

- Check that isolation and bypass valves have been positioned correctly to suit filtration pump
- Check the spa water level is OK and confirm that water is flowing freely into filter area
- Check there is adequate water flow. If no flow, bleed air locks from pipe work
- Inspect pipe work and follow flow direction to ensure water is flowing out of the spa into the bottom inlet pipe on the heat pump, flowing out of the top outlet pipe on the heat pump and returning to the spa. If heat pump has been plumbed in reverse direction, correct plumbing or rotate direction of flow switch 180 degrees.
- Check filtration pump operation for internal thermal cut out operation or motor stall.

Existing installs:

- Check the spa water level is OK, refill if necessary
- Clean or replace filter cartridges
- If the spa has just been emptied/refilled, bleed air locks from pipe work
- Check filtration pump is working OK and has not seized

NO HEAT PUMP OPERATION

- Check SV spa controller settings. Confirm that H.PMP setting has not disabled the heat pump.
- Confirm ambient air temperature is within operational limits.
- Check there is no hammer and spanner error symbol on the display. If error symbol is present, wait for the error code to scroll every 30 seconds and take corrective action accordingly.
- Check that the heat pump power source is OK. Check RCD safety switch has not tripped.
- Check power and data cables for signs of damage. Replace cables if damaged.
- Inspect internal heat pump PCB for damage or blown fuse (NOTE: Ensure power is isolated and turned OFF before inspecting heat pump. Work should be performed by a qualified person).

THERMAL CUT OUT ERRORS

- Check for poor filtration pump flow performance.
- Confirm ambient air temperatures are within operational limits.
- Confirm heat pump air space is clear and not obstructed by and vegetation or objects.

NOT ENOUGH HEATING

Heat pump works normally but there is no or insufficient heating:

- First check the ambient temperature, water temperature, and estimate the related heating capacity.
- Check if the heat pump has a ventilation obstacle.
- Check the general power supply is correct and amperage draw from heat pump is as expected.
- Check the refrigerant inside is enough. If level is low find the gas leakage and recharge the unit.
- Lots of ice formation on evaporator.
 - Solutions :
 - check the temperature sensors are calibrated.
 - Insufficient air flow – check install location, confirm fan is working and remove any debris on or near evaporator. Contact your spa reseller for further assistance

12. Heat Pump Error Codes

If a heat pump fault condition is detected a hammer & spanner symbol appears on the SV touch pad display with a warning message scrolled across the LCD every 30 seconds. The heat pump is disabled until the mains power to the SV spa control is reset. Spa operation and heating will continue however the spa will now heat with the SV spa controls internal electric heating element and there will be no ability to cool the water.



WARNING The heat pump warning message will continue to scroll every 30~60 seconds, and the heat pump will remain disabled until the mains power is turned OFF and back ON again.

A list of the fault conditions and warning messages are detailed below for reference.

ERROR MESSAGE	DESCRIPTION
HEAT PUMP AMB	Ambient temperature sensor error
HEAT PUMP COND	Condenser/Evaporator temperature sensor error
HEAT PUMP FLOW	Water flow not detected
HEAT PUMP LOW P	Compressor low pressure switch open
HEAT PUMP HIGH P	Compressor high pressure switch open
HEAT PUMP COMP	Compressor thermal cut out open
HEAT PUMP EXCH	Heat exchanger thermal cut out open

Trouble shooting tips for each error code are detailed below for reference:

HEAT PUMP AMB

No signal from ambient temperature sensor, or signal is corrupted

- Check ambient sensor is connected to heat pump pcb
- Inspect data cable for damage and check data cable connected correctly to SV spa control
- Disconnect/reconnect data cable from SV spa control and reset mains power
- Replace data cable if problem unresolved (use double-shielded CAT5/CAT6 Ethernet cable)

HEAT PUMP COND

No signal from condenser temperature sensor, or signal is corrupted

- Check condenser sensor is connected to heat pump pcb
- Inspect data cable for damage and check data cable connected correctly to SV spa control
- Disconnect/reconnect data cable from SV spa control and reset mains power
- Replace data cable if problem unresolved (use double-shielded CAT5/CAT6 Ethernet cable)

HEAT PUMP FLOW

No or insufficient water flow passing through heat pump

- Refer water flow tips in first part of Troubleshooting section on prior pages

HEAT PUMP LOW P

No signal from low pressure switch or insufficient refrigerant gas charge

- Check low pressure switch is connected to heat pump pcb
- Check refrigerant level, if low have heat pump checked by a refrigeration technician

HEAT PUMP HIGH P

No signal from high pressure switch or refrigerant pressure too high due to heat

- Check high pressure switch is connected to heat pump pcb
- Check water flow is OK (low water flow rates could cause high pressure errors)
- Confirm ambient air temperatures are within operational limits and fan is working

NOTE: In extreme environmental weather conditions (i.e. ambient temp > 38°C), depending on heat pump location & environment and nearby obstructions and air flow restrictions (i.e. fences, plants, walls) if the heat pump is used for COOLING, the refrigerant may exceed its working capacity and shut down on high pressure error. To prevent this, **the heat pump should only be used for COOLING at times of day/night when ambient temperatures are lower, and prior to extreme hot weather.**

HEAT PUMP COMP

Compressor has overheated or thermal cut out signal is corrupted

- Confirm ambient air temperatures are within operational limits and fan is working
- Turn mains power OFF, leave heat pump for 45 minutes for compressor to cool and test again
- Inspect data cable for damage and check data cable connected correctly to SV spa control
- Replace data cable if problem unresolved (use double-shielded CAT5/CAT6 Ethernet cable)

HEAT PUMP EXCH

Water temperature in heat exchange tank exceeds 50°C or thermal cut out signal is corrupted

- Check spa water level and ensure water flow from filtration pump is OK
- Clean or replace spa filter cartridges to improve water flow
- Inspect data cable for damage and check data cable connected correctly to SV spa control
- Replace data cable if problem unresolved (use double-shielded CAT5/CAT6 Ethernet cable)

If after following the troubleshooting tips and resetting mains power the fault condition persists please contact your spa reseller and report the warning message/error code that is shown.

13. Wiring Diagram

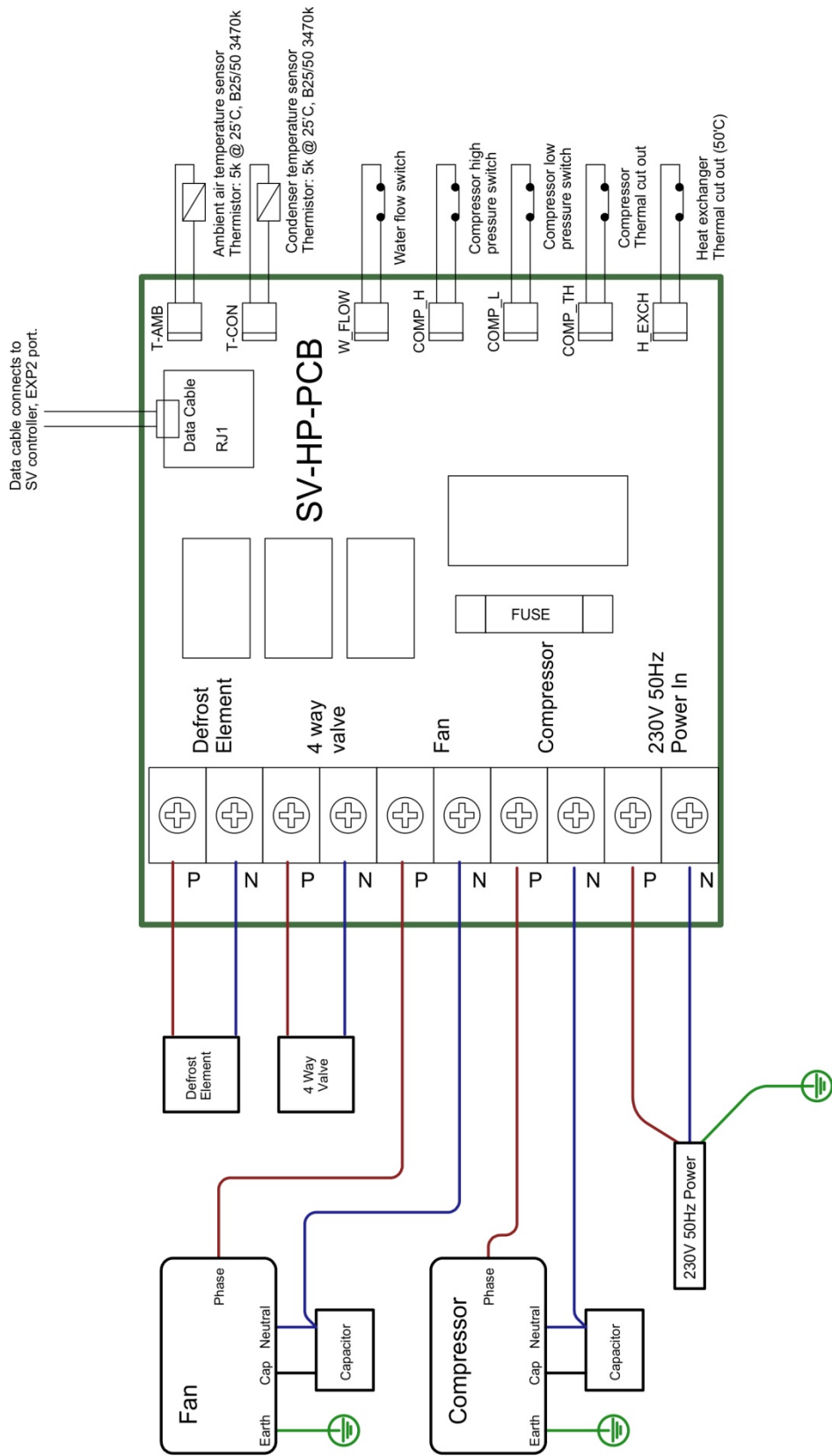

NOTE : This diagram is correct at the time of publication, manufacturing changes could lead to modifications. Always refer to the diagram supplied with the heat pump.

Contact Us

Spa Net Pty Ltd

Unit 4
103 Railway Road North
Mulgrave NSW 2756
Australia

Phone: +61 2 4587 7766

Fax: +61 2 4587 8766

www.spanet.com.au

Technical Support & Service service@spanet.com.au

Accounts Department accounts@spanet.com.au

Sales Department sales@spanet.com.au